

Motorized Roller Blind

# ATF35-RB

Mar. 2021  
RENEWAL

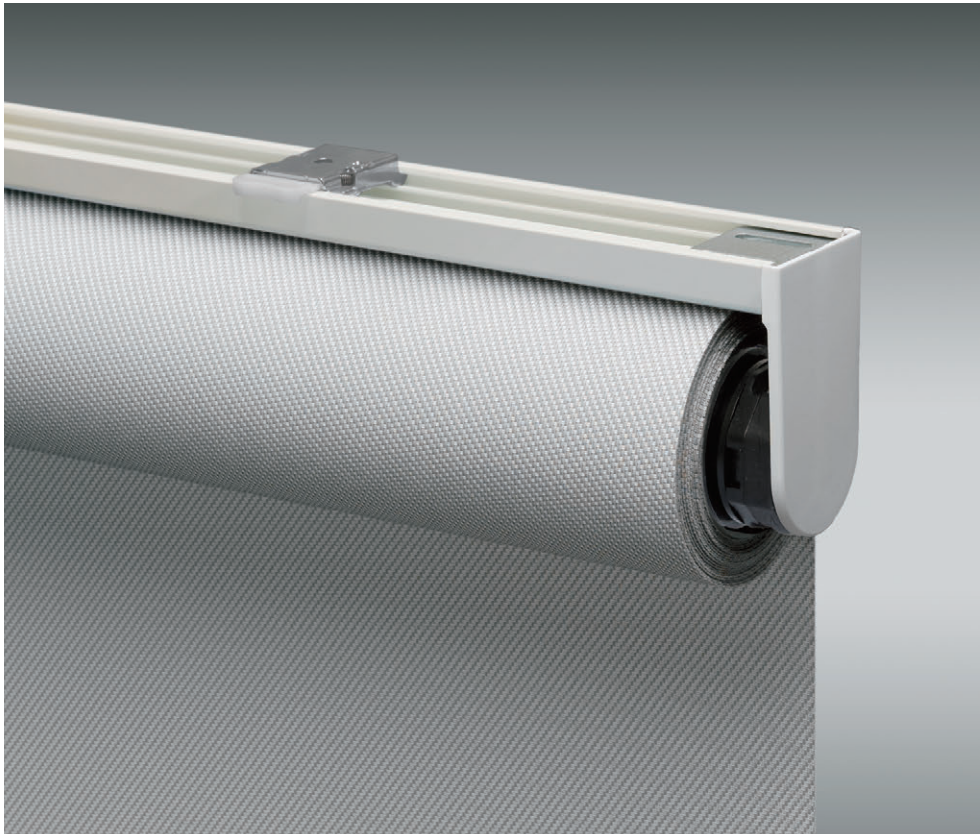

- Exceptionally compact motorized roller blind.
- Two installation options are available: a neatly-fixed option, Side Bracket type or an easy-to-install option, Set Bar type.
- Switch operation type and FM remote type are available.

# ATF35-RB

## ATF35-RB's Unique Features

This compact design motorized roller blind offers a variety of uses: from commercial to home.

Easy Snap Bracket is available for easy installation and removal. (Set Bar type)

ATF35 tubular motor realizes quiet operation. (less than 40 dB)

At the Set bar type, the gap between Side Brackets and a screen is small.

Motor for switch operation and motor (built-in FM Receiver) are available.

## Structure Drawing

Side Bracket Type

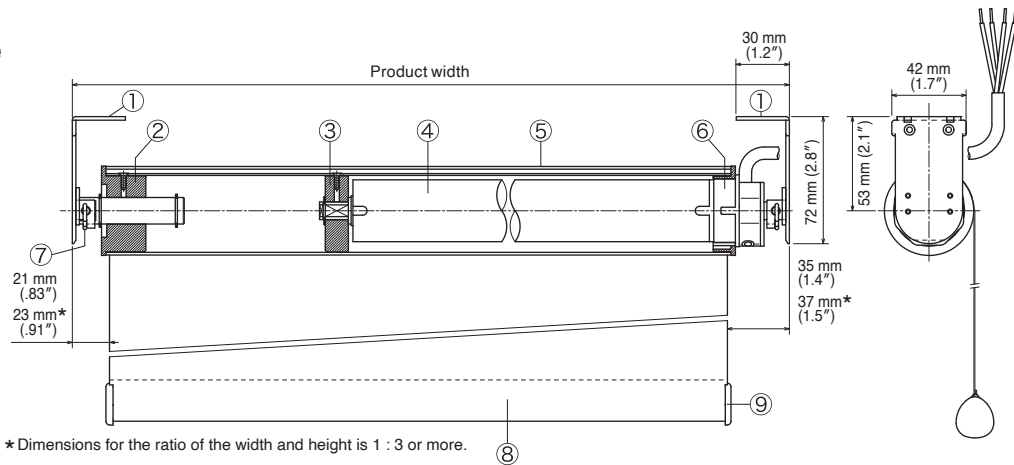

Set Bar Type

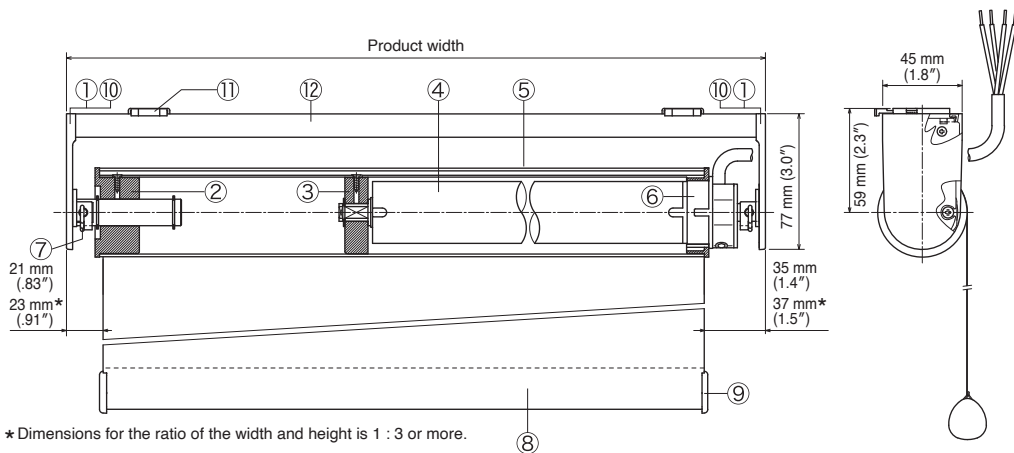

## Components and Materials

Side Bracket Type

No.	Components	Material
①	ATF35-04 End Side Bracket	Stainless steel
②	ATF35 Pipe End	Polyacetal resin
③	ATF35-05 Drive	Polyacetal resin
④	ATF35-05 / 05RF Tubular Motor	—
⑤	ATF35 Roller Pipe ø 50	Aluminum
⑥	ATF35 Limit Crown	Polyacetal resin
⑦	Split Pin	Steel
⑧	MT03 Weight Bar	Aluminum
⑨	MT03 Weight Bar Cap	Polyethylene resin

Set Bar Type

No.	Components	Material
①	ATF35-04 End Side Bracket	Stainless steel
②	ATF35 Pipe End	Polyacetal resin
③	ATF35-05 Drive	Polyacetal resin
④	ATF35-05 / 05RF Tubular Motor	—
⑤	ATF35 Roller Pipe ø 50	Aluminum
⑥	ATF35 Limit Crown	Polyacetal resin
⑦	Split Pin	Steel
⑧	MT03 Weight Bar	Aluminum
⑨	MT03 Weight Bar Cap	Polyethylene resin
⑩	Side Cover	AES resin
⑪	MT01N Bracket	Steel
⑫	MT01N Set Bar	Aluminum

**Motor Specifications**

Power Source Voltage	V	AC220-230
Frequency	Hz	50/60
Current	A	0.485
Power Consumption	W	115
Rated Torque	Nm	4
Rated RPM	rpm	23
Rated Running Time	min.	4
Ambient Temperature	°C	-10 to 40

\*Since this is not synchronized motor, RPM is vary depending on fabric weight.

**Allowable Size**

Width	ATF35-05	600-2,000 mm (24-79")
	ATF35-05RF	700-2,000 mm (28-79")
Height		500-4,500 mm (20-177")
Max Surface Area		9 m <sup>2</sup> (11 yd <sup>2</sup> )

**Product Weight**

4.2 kg (9.3 lb)  
(width: 2,000 mm/79" without screen)

\*On Side Bracket type.

**Typical Roll-up Diameter**

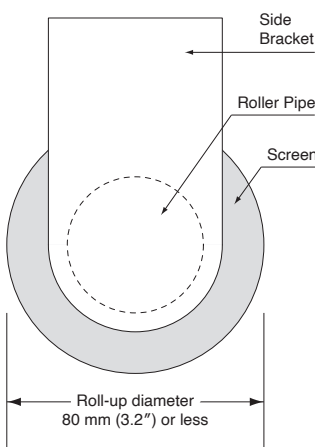

Thickness	Height	Roll-up Diameter								
		500 mm (20")	1,000 mm (39")	1,500 mm (59")	2,000 mm (79")	2,500 mm (98")	3,000 mm (118")	3,500 mm (138")	4,000 mm (158")	4,500 mm (177")
0.1 mm	Roll-up diameter	44	45	46	47	47	48	49	49	50
	Number of rolling	7	11	14	18	21	25	28	31	34
0.2 mm	Roll-up diameter	46	47	49	50	51	52	54	55	56
	Number of rolling	7	11	14	17	20	23	26	29	32
0.3 mm	Roll-up diameter	47	49	51	53	55	56	58	60	61
	Number of rolling	7	10	14	17	20	22	25	28	31
0.4 mm	Roll-up diameter	49	51	54	56	58	60	62	64	66
	Number of rolling	7	10	13	16	19	22	24	27	29
0.5 mm	Roll-up diameter	50	53	56	59	61	64	66	69	71
	Number of rolling	7	10	13	16	18	21	23	26	28
0.6 mm	Roll-up diameter	51	55	58	61	64	67	70	73	75
	Number of rolling	7	10	13	15	18	20	23	25	27
0.7 mm	Roll-up diameter	52	56	60	64	67	70	74	77	79
	Number of rolling	7	10	12	15	17	20	22	24	26
0.8 mm	Roll-up diameter	54	58	62	66	70	74	77	-	-
	Number of rolling	7	9	12	15	17	19	21	-	-

**FM Remote-Control Transmitter**

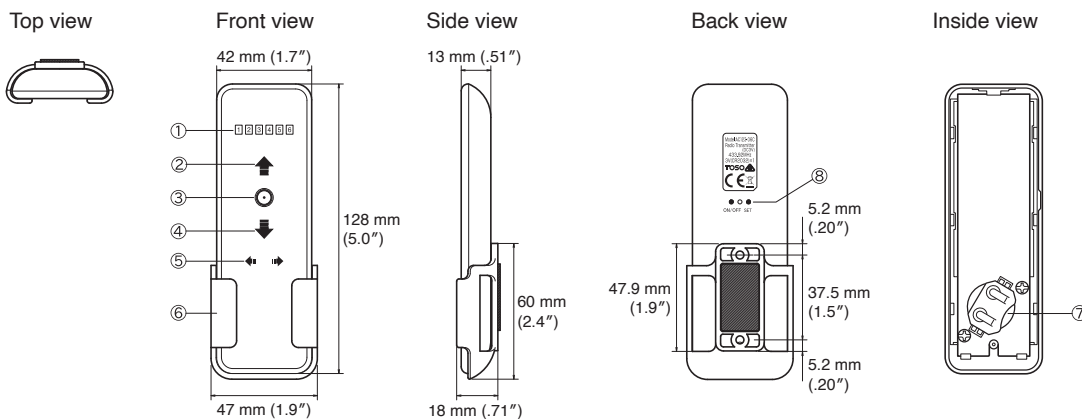

**Parts Name**

①	Address No. LED Indicator Lamp
②	Open Button
③	Stop Button
④	Close Button
⑤	Address No. Setting Button
⑥	Holder
⑦	Battery (CR2032)
⑧	ON/OFF Button

**Specification**

Source Voltage	DC 3V (CR2032 × 1)
Source Current	20 mA or lower
Wave Frequency	433.92 MHz
Number of Channel	1 to 6 (ALL for 6 CH)
Ambient Temperature	-10 to 50°C (Non-condensing)
Reaching Distance	30 m (varies depending on the condition)
Product Size	W 42 mm × H 128 mm × D 13 mm
Product Weight	Approx. 58 g

Overall Structure Drawing

Side Bracket Type

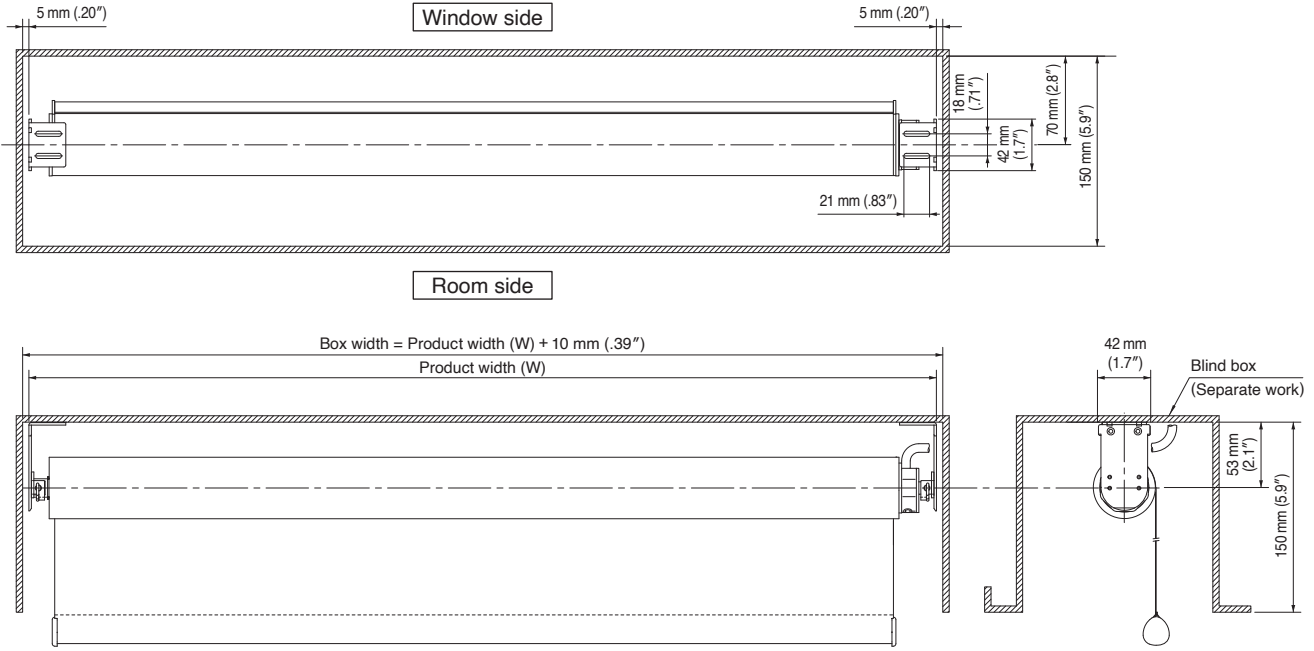

Set Bar Type

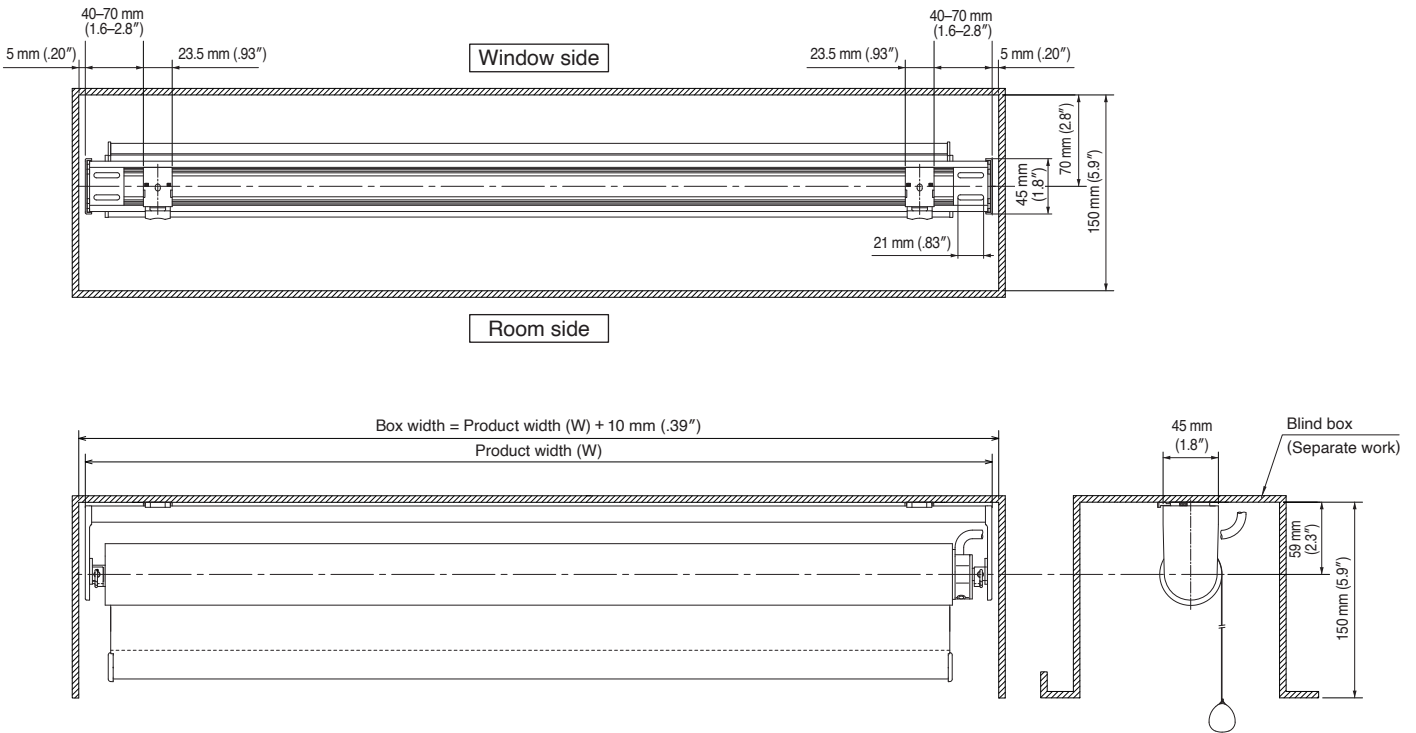

Exploded View

Side Bracket Type

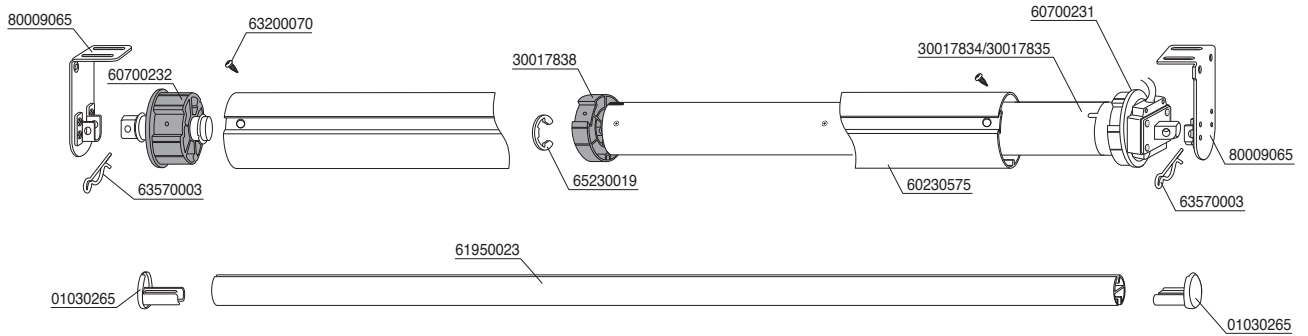

Set Bar Type

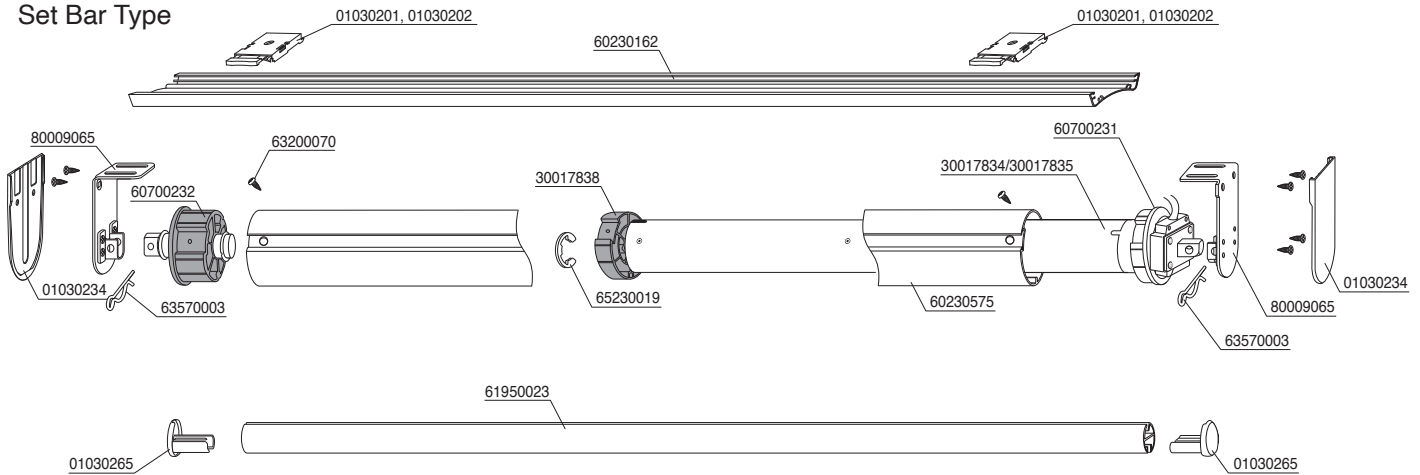

Parts and Components

Item No.	Product Name	Side Bracket Type	Set Bar Type
30017834	ATF35-05 Tublar Motor	1 pc	1 pc
30017835	ATF35-05RF Tublar Motor		
60700231	ATF35 Limit Crown	1 pc	1 pc
30017838	ATF35-05 Drive	1 pc	1 pc
60700232	ATF35 Pipe End	1 pc	1 pc
60230575	ATF35 Roller Pipe φ 50 2000 mm (79")	W-62 mm (W-2.4")	W-41 mm (W-1.6")
80009065	ATF35-04 End Side Bracket	2 pcs	2 pcs
60230162	MT01N Set Bar White 2800 mm (110")	—	W-7 mm (W-.28")

Item No.	Product Name	Side Bracket Type	Set Bar Type
01030201	MT01N Bracket (2 pcs)	—	Up to W1,000 mm (39"): 1 set
01030202	MT01N Bracket (3 pcs)	—	W1,010 mm (40") or over: 1 set
01030265	MT03 Weight Bar Cap White	2 pcs	2 pcs
61950023	MT03 Weight Bar White 2,730 mm (108")	[W:H=1:3] or over: W-69 mm (2.7") Up to [W:H=1:3]: W-65 mm (2.6")	[W:H=1:3] or over: W-48 mm (1.9") Up to [W:H=1:3]: W-44 mm (1.7")
63570003	Split Pin	2 pcs	2 pcs
65230019	Retaining Ring	1 pc	1 pc
63200070	Tapping Screw 3 x 10	6 pcs	6 pcs
01030234	Side Cover White	—	2 pcs

## Basic Wiring and Connecting Diagram

### Single Operation (ATF35-05)

Basic Wiring Diagram

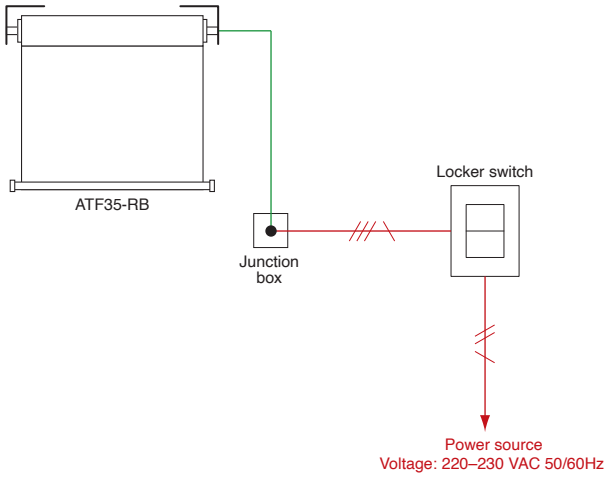

Basic Connecting Diagram

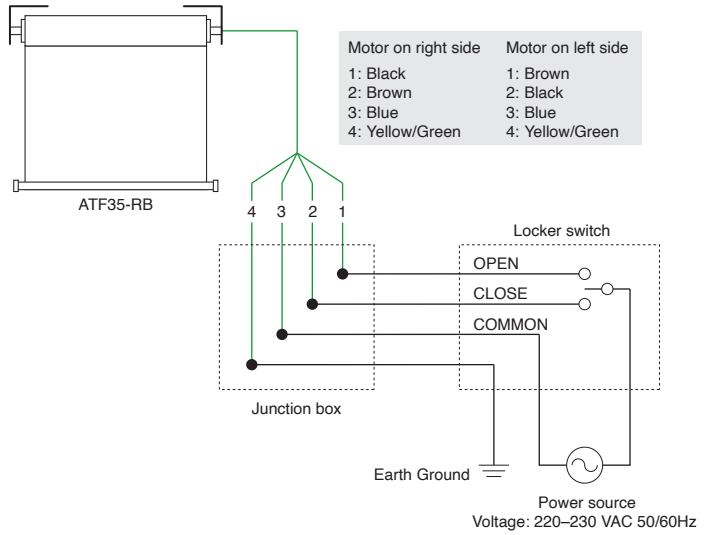

### FM Remote-Control Built-in Receiver (ATF35-05RF)

Basic Wiring Diagram

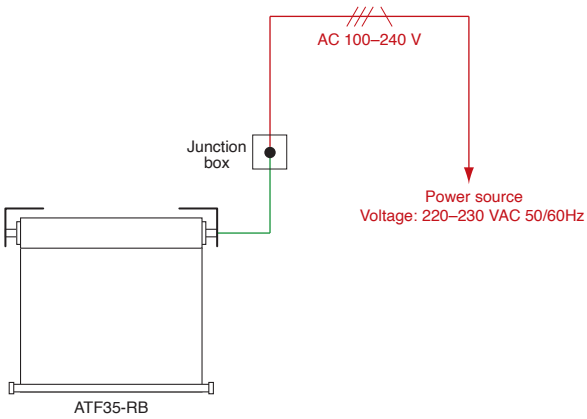

Basic Connecting Diagram

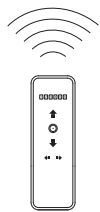
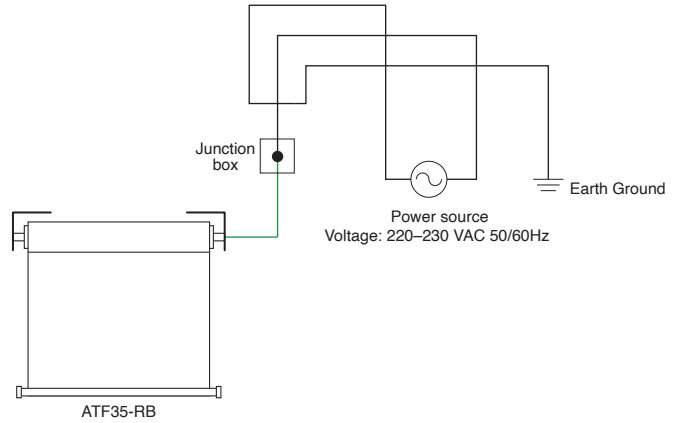



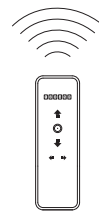



FM Remote-Control Transmitter

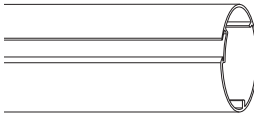
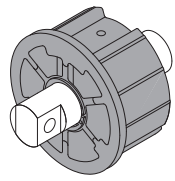
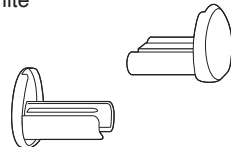
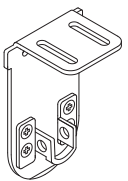

FM Remote-Control Transmitter

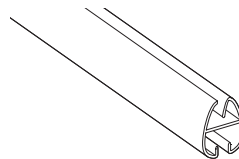
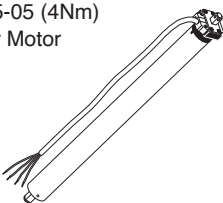
Explanatory notes: — Power supply, — Main body attachment or TOSO standard

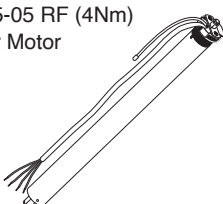
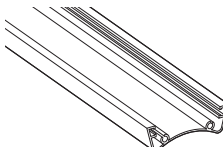
ATF35-RB Parts

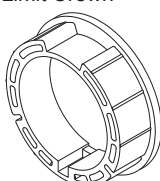
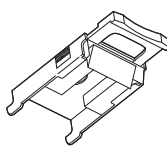
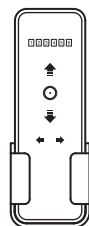
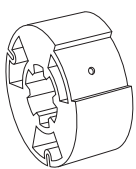
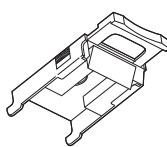
Product Name	Product Code	Product Name	Product Code	Product Name	Product Code
ATF35 Roller Pipe Ø 50 2000 mm 	60230575	ATF35 Pipe End 	60700232	MT03 Weight Bar Cap White 	01030265
ATF35-04 End Side Bracket 	80009065	Split Pin 	63570003	MT03 Weight Bar White 2730 mm 	61950023
ATF35-05 (4Nm) Tublar Motor 	30017834	Retaining Ring 	65230019	Side Cover White 	01030234
ATF35-05 RF (4Nm) Tublar Motor 	30017835	MT01N Set Bar White 2800 mm 	60230162	Tapping Screw 3 × 10 	63200070
ATF35 Limit Crown 	60700231	MT01N Bracket (2 pcs) 	01030201	FM Remote-Control Transmitter (6 channels) 	30006891
ATF35-05 Drive 	30017838	MT01N Bracket (3 pcs) 	01030202		

